

weldcote 

Quick Guide Manual

# MIG STRIKER 200

MULTI-PROCESS  
(STICK/MIG/TIG) WELDING  
MACHINE FOR STEEL,  
STAINLESS STEEL AND  
ALUMINIUM

WELDING FOR WELL-BEING



## SAFETY WARNING

On the process of welding or cutting, there will be possibility of injury, so please take protection into consideration during operation. For more details please review the Operator Safety Guide, which complies with the preventive requirements of the manufacturer.

### **Electric shock - May lead to death!!**

- Set the earth fitting according to applying standard.
- Do not touch the bare electric parts and electrode with uncovered skin, wet gloves or clothes.
- Make sure you are insulated from the ground and the workshop.
- Make sure you are in safe position.

### **Gases and fumes - May be harmful to health!!**

- Keep your head out of the gases and fumes.
- When arc welding, ventilators or air extractors should be used to avoid breathing gases.

### **Arc rays - Harmful to your eyes, burn your skin**

- Wear suitable protective mask, light filter and protective garment to protect eyes and body.
- Prepare suitable protective mask or curtain to protect looker-on.

### **Fire**

- Welding sparks may cause a fire, make sure there are no flammable objects or chemicals nearby.

### **Noise - Excessive noises will be harmful to hearing**

- Use hearing protection or others means to protect ear.
- Warn looker-on that noise is harmful to hearing.

### **Having trouble? Connect with authorized professionals**

- If trouble happens during installation and operation, please follow this manual instruction to check up.
- If you fail to fully understand the manual, or fail to solve the problem with the instruction, you should contact the suppliers or the service center for professional help.



## **WARNING!**

**Thermal Magnetic Auto Circuit Breaker protecting switch should be used with the machine.**

## 1.1 EQUIPMENT

---

- Repair and maintenance to be performed by authorized personnel only.
- The welding machine is to be maintained in good operational conditions (dry and clean).
- The welding machine is not to be positioned in a closed space or next to a wall while welding in order to avoid problems with venting.
- The welding machine is to be properly connected to the power grid.
- avoid pulling on the power cable when moving the welding machine.
- the welding handle and work cable are to be properly maintained.
- Electricity is dangerous and loose connections can lead to injury and poor welding.

## 1.2 WORK AREA

---

The welding arc emits sparks, fumes and radiation

- Remove all flammable materials and items from your work area.
- Ensure proper ventilation at the work area.
- Do not weld tanks or pipes that contain or used to contain flammable liquid or gas (danger of explosion or fire) or were cleaned by chlorine-based detergents (danger of toxic fumes).

## 1.3 OPERATOR

---

- Avoid coming in direct contact with the welding circuit. The open circuit voltage between the electrode holder, the work cable and the work piece is dangerous.
- Do not weld when it is raining or in wet or damp places.
- Always use protective equipment DIN 9-10, including long sleeved pants and vest, gloves, welding helmet of proper rating and hat. Avoid exposing the skin to the welding UV radiation.



### ALWAYS REMEMBER

---

- The radiation emitted by the welding arc can cause damage to the eyes and burns to the skin.
- The welding arc emits sparks and droplets of molted metal at very high temperatures, these stay hot for a relatively long time.
- The welding fumes produced when welding are dangerous.
- Every electrical shock is dangerous.
- Avoid direct exposure of the skin from the welding arc at a range of 15 meters.
- Take proper precautions to protect yourself and others from the potential dangers of the welding arc.

## 2.0 GENERAL INFORMATION

---

### 2.1 DESCRIPTION

---

1. Digital current display
2. Welding current adjustment
3. Digital voltage display / wire speed
4. Dial for adjusting voltage/down slope/arc force
5. POWER ON indication light - is on when the welding machine is connected to a live socket and is on.
6. ALARM indication light - is on in case of under voltage, over current, or over heat, this pilot lamp indicates when lit that the protection of the machine has been activated.
7. Inductance adjusting knob (STICK: adjust the arc force; TIG: adjust down slope time; MIG: fine adjust welding voltage 10~25V).
8. Wire diameter selection - voltage and amperage automatically adjust according to the diameter. For manual selection choose MAN. Voltage and Wire Speed still operate, but are pre-set to the recommended values.
9. Welding material selection. MS - Mild Steel, Al - Aluminum, SS - Stainless Steel.
10. Manual/Automatic (2T/4T) operation mode selection
11. Welding mode selection (MIG/TIG/Stick)
12. MIG gun quick connector - the MIG welder's positive polarity output.
13. Positive terminal quick connection (+)
14. Shield gas connector - Is connected to the gas input pipe of the torch
15. TIG gun quick connector
16. Negative terminal quick connection (-)
17. Shield gas input joint to the gas cylinder
18. ON/OFF switch
19. Input power cable connection
20. Burn Back adjustment - increase to prevent wire sticking to the workpiece.
21. Spool Gun / MIG Gun selector switch - select according to the gun used.
22. Polarity selector - jumper plate to be placed according to welding polarity needed (change to "-" position, and earth cable connects to "+" on front panel when using self-shielding wire).
23. 11lb spool (8" outer diameter).
24. Drive Roll - groove diameter to be according to wire diameter used.

---

Single phase inverter with voltage reduction for direct current welding using coated electrodes, MIG spools and TIG rods.

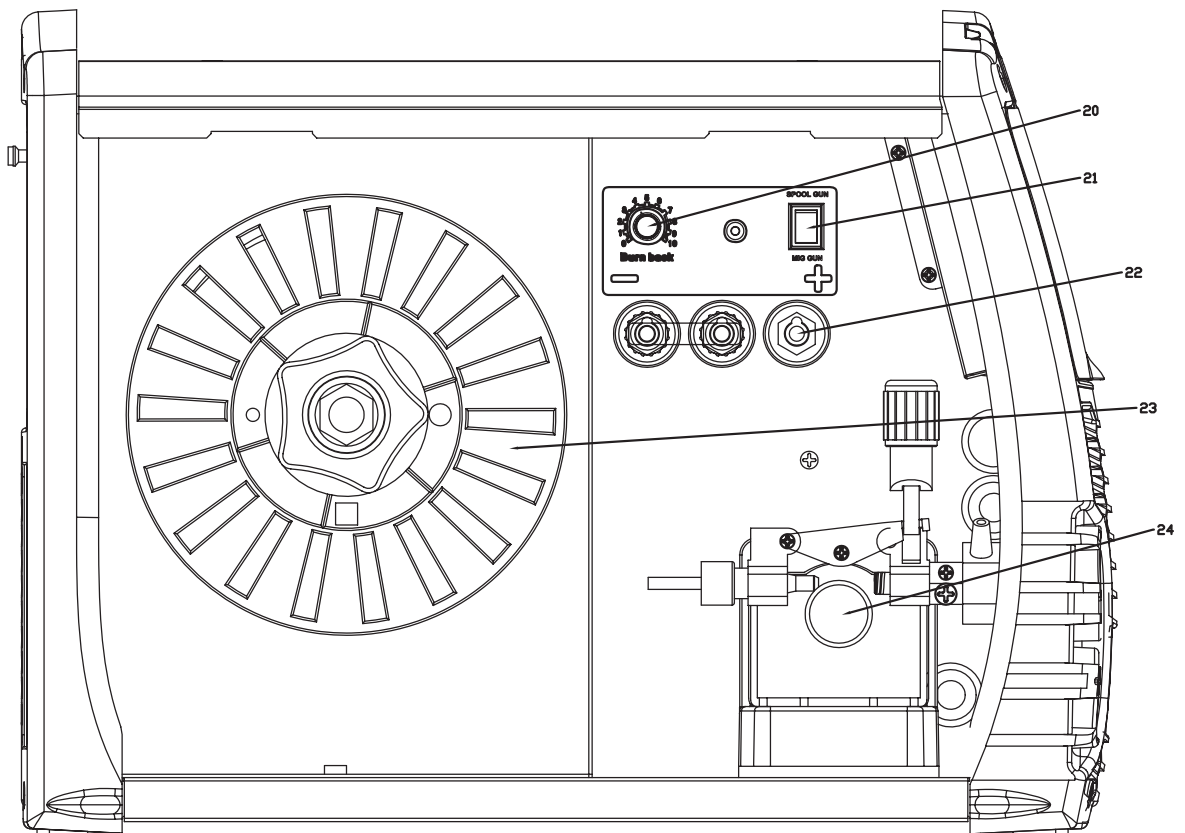
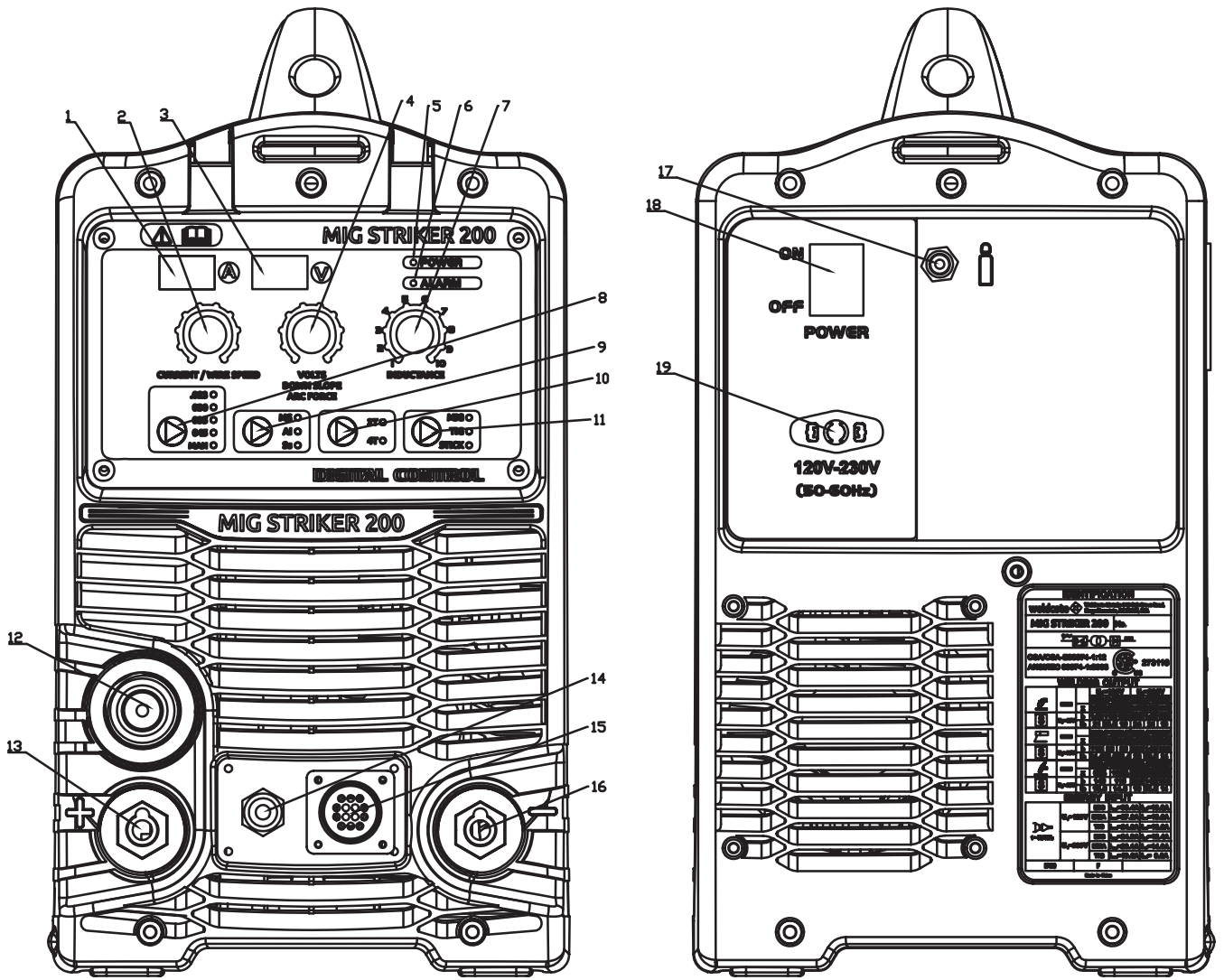

## 2.2 PARAMETERS

PARAMETERS	MIG STRIKER 200		
	MIG	TIG	STICK
Input Voltage (A)	1~120±10% <sup>①</sup> 1~230±10%		
Rated Input Current (A)	32 <sup>①</sup> 26.1	25.5 <sup>①</sup> 20.3	28 <sup>①</sup> 30.2
Rated Input Power (KW)	3.9 <sup>①</sup> 5.7	2.9 <sup>①</sup> 4.5	3.4 <sup>①</sup> 6.7
Welding Current Range (A)	10~140 <sup>①</sup> 10~200	10~140 <sup>①</sup> 10~200	10~110 <sup>①</sup> 10~200
Welding Voltage (V)	10~26	-	-
No-load Voltage (V)	45 (controlled)		
Duty Cycle (A) 104°F, 10 minutes (%)	35% 140A <sup>①</sup> 60% 115A <sup>①</sup> 100% 100A <sup>①</sup>	60% 140A <sup>①</sup> 100% 115A <sup>①</sup>	50% 110A <sup>①</sup> 60% 95A <sup>①</sup> 100% 85A <sup>①</sup>
Duty Cycle (A) 104°F, 10 minutes (%)	25% 200A 60% 140A 100% 100A	25% 200A 60% 140A 100% 100A	25% 200A 60% 140A 100% 100A
Efficiency (%)	75 <sup>①</sup> 84	76 <sup>①</sup> 81	79 <sup>①</sup> 84
Power Factor	0.99		
Cooling	AF		
Protection Class	IP23		
Wire Diameter	MS: .023/030/035/045 Al: 035/045 Flux: 035 (self-shield)/045		
Insulation Class	F		
Net Weight	39.2		
Dimensions of Powersource (length×width×height)	18.5"×8.8"×16.6"		
Dimensions of Carton Box (length×width×height)	21.6"×13.8"×11.4"		

① - Parameters when on 120V power supply

## 2.3 SPECIAL FEATURES

- **PFC** - correction and dumping circuits in the machine increase power efficiency, reducing input power requirements, and stabilizing welding current.
- **MIG ALUMINUM** - Welding with aluminum spools or spool gun with Synergic settings.
- **HOT START** - Easy ignition of the welding arc.
- **ARC FORCE** - Prevents sticking of the electrode to the workpiece.
- **SPOOL GUN READY** - Spool gun compatible (purchased separately).
- **VRD** - Reduce Voltage at no-load condition for safer work.
- **SMART FAN** - Power saving and reduction of dust as well as improved fan working life.
- **DUAL VOLTAGE** - Automatically identify the power grid voltage (120V or 230V) and operates accordingly 120V to 230V adapter included.

## 3.0 INSTALLATION

---

### 3.1 MAIN CONNECTIONS

---

Before connecting to the power grid, verify the supply voltage is in range of the machine parameters.

- The power cable plug is to be connected to standard approved socket, with the proper protections.
- The ground line (green & yellow) is to be connected to the grounding pin.

### 3.2 MIG WELDING OPERATION

---

#### 3.2.1 MOUNTING THE WIRE SPOOL

---

The machine is designed to use 11lb spools (8" outer diameter)

The wire spools are not supplied with the machine and must be purchased separately.

Make sure the shielding gas and electrical power are disconnected.

- Use a CO2 or mixed gas Cylinder equipped with a pressure regulator. Connect the flexible hose between the regulator and the machine (17). Tighten the bands.
- Connect the ground cable quick connection between the machine (negative terminal (16) when using solid wire) and the work piece.
- Mount the wire spool (B) over the shaft (C) and tight with the nut (F).
- Choose the proper feeder grooved wheel (1 or 2) according to the wire diameter used.
- Release the screw in the feeder mechanism and insert the wire through the tube. Close and tighten the screw to have the feeder wheel hold the wire in place.
- Connect the MIG torch cable quick connector over the protruding wire. Feed the wire all through to the torch, and screw a contact tip over it.

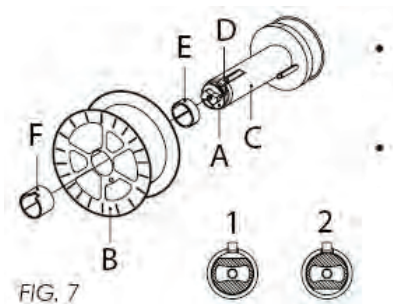
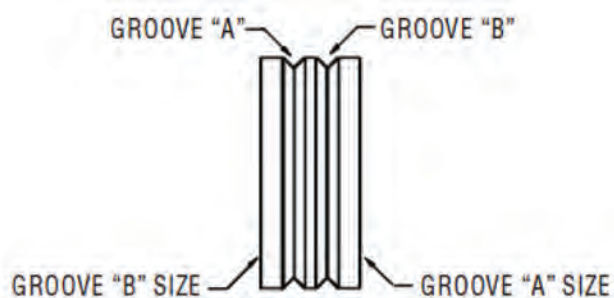

### 3.2.2 SETUP FOR MIG-GUN MIG (GMAW) WELDING WITH GAS SHIELDED MIG WIRE

---

- A.** Select MIG mode with the process selection control (11).
- B.** In most cases the MIG polarity selector (22) is to be connected to the negative position (-), as shown in the sketch. If in doubt, consult the wire manufacturer.
- C.** Fit the MIG Gun to the power source using the front panel connection socket (12).
- D.** Connect the work lead to the negative welding terminal (16). If in doubt, consult the wire manufacturer. Welding current flows from the Power Source via heavy duty bayonet type terminals. It is essential, however, that the male plug is inserted and turned securely to achieve a sound electrical connection.
- E.** Fit the welding grade shielding gas regulator/flowmeter to the shielding gas cylinder, then connect the shielding gas hose from the rear of the power source (17) to the regulator/flowmeter outlet, using the supplied quick-connect adaptor.
- F.** Select manual or automatic operation (10).
- G.** Select workpiece material (9).
- H.** Select wire diameter of the spool installed (8)
- I.** Make sure the feed roll used corresponds to the same diameter (24)
- J.** Set the Welding Gun Switch located inside the wire drive compartment (21), to MIG GUN.

### 3.2.3 SETUP FOR SPOOL GUN MIG (GMAW) WELDING WITH GAS SHIELDED MIG WIRE

---

- A.** Select MIG mode with the process selection control (11).
- B.** In most cases the MIG polarity selector (22) is to be connected to the negative position (-), as shown in the sketch. If in doubt, consult the wire manufacturer.
- C.** Fit the Spool Gun to the power source using the front panel connection socket (12).
- D.** Connect the work lead to the negative welding terminal (16). If in doubt, consult the wire manufacturer. Welding current flows from the Power Source via heavy duty bayonet type terminals. It is essential, however, that the male plug is inserted and turned securely to achieve a sound electrical connection.
- E.** Fit the welding grade shielding gas regulator/flowmeter to the shielding gas cylinder, then connect the shielding gas hose from the rear of the power source (17) to the regulator/flowmeter outlet, using the supplied quick-connect adaptor.
- F.** Select manual or automatic operation (10).
- G.** Select workpiece material (9).
- H.** Select wire diameter of the spool installed in the SPOOL GUN(8)
- I.** Set the Welding Gun Switch located inside the wire drive compartment (21), to SPOOL GUN.



### 3.2.4 SETUP FOR WELDING WITH SELF SHIELDED MIG WIRE

---

- A. Follow the above steps according to the type of welding gun used (3.2.1 or 3.2.2), with the following differences is steps B and E:
- B. In most cases the MIG polarity selector (22) is to be connected to the negative "-", and earth cable connects to "+" on front panel. If in doubt, consult the wire manufacturer.
- E. No shielding gas is needed.

### 3.3 ARGON ARC WELDING OPERATION

---

#### 3.3.1 TIG WELDING (4T OPERATION)

---

The start current and crater current can be pre-set. This function can compensate the possible crater that appears at the beginning and end of the welding.

**Introduction:**

**0:** Press and hold the gun switch, Electromagnetic gas valve is turned on.

The shielding gas starts to flow;

~ **0t1:** Pre flow time, adjustment range of pre flow time :0.1~1.0S;

~ **t1:** Striking success, adjustment range of start current: 5~200A;

~ **t2:** Release the gun switch, the output current slopes up from start current;

**t2~t3:** Output current slopes up to the setting current value; adjustment range of up slope time 0~10.0S ;

**t3~t4:** Welding process. During this period, the gun switch is released;

**Note:** the output current is DC current;

**t4:** Repress down the gun switch, the output current slopes down to crater current;

**t4~t5:** Down slope time, adjustment range of down slope time: 0~10.0S;

**t5~t6:** Crater current holds time; adjustment range of crater current: 5~200A;

**t6:** Release switch, stop arc, gas will post flow;

**t6~t7:** Post flow time, adjustment range of post flow time: 0.1~10.0S;

**t7:** Electromagnetic valve is closed and stop argon flowing. Welding is finished.

#### 3.3.2 TIG WELDING (2T OPERATION)

---

TIG short welding (2T)

**Introduction:**

**0:** Press and hold the gun switch, Electromagnetic gas valve is turned on. The shielding gas starts to flow;

~ **0t1:** Pre flow time, adjustment range of pre flow time: 0.1~1.0S;

**t1~t2:** Striking success, the output current slopes up to the setting current from minimum

current (5A)

**t2~t3:** During the whole welding process, the gun switch is pressed and held without releasing;

**t3:** Release the gun switch, the output current slopes down;

**t3~t4:** The output current slopes down to minimum current (5A), stop arc; adjustment range of down slope time: 0~5S;

**t4~t5:** Post flow time, adjustment range of post flow time: 0.1~10.0S;

**t5:** Electromagnetic valve is closed and stop argon flowing. Welding is finished.

#### **Short circuit protect function:**

**1. TIG /DC/LIFT:** If the tungsten electrode touches the workpiece when welding, the current will drop to 30A, which can reduce the tungsten spoilage and significantly prolong the life of the tungsten electrode and prevent tungsten clipping.

**2. STICK operation:** if the electrode touches workpiece over two seconds, the welding current will drop to 0 automatically to protect the electrode.

#### **Notices:**

- Check the condition of welding and connection units firstly, otherwise there will be malfunction such as ignition spark/gas leakage/out of control and so on.
- Check that whether there is enough Argon gas in the shield gas cylinder, you can test the electromagnetic gas valve through the switch on the front panel.
- The flow rate is set according to the welding power used in the job. Turn the regulation screw to adjust the gas flow which is shown on the gas hose pressure meter or the gas bottle pressure meter.

### **3.4 SETUP FOR STICK (MMA) WELDING**

---

**A.** Connect the Electrode Holder lead to the positive welding terminal (13).

If in doubt, consult the electrode manufacturer. Welding current flows from the Power Source via heavy duty bayonet type terminals. It is essential, however, that the male plug is inserted and turned securely to achieve a sound electrical connection.

**B.** Connect the work lead to the negative welding terminal (16). If in doubt, consult the electrode manufacturer. Welding current flows from the power source via heavy duty bayonet type terminals. It is essential, however, that the male plug is inserted and turned securely to achieve a sound electrical connection.

**C.** Select STICK mode with the process selection control (11).

## 4.0 WELDING ACCESSORIES: CONNECTION AND APPLICATION

---

### 4.1 WORK LEAD WITH WORK CLAMP

---

The work clamp is to be connected directly to the work piece or the work table with good electrical continuity to the work piece.

**Careful!** Avoid using coated or non-metallic, non-conducting work-benches.

### 4.2 WELDING LEAD WITH ELECTRODE HOLDER

---

This cable has a special handle that holds the exposed part of the coated electrode.

### 4.3 WELDING LEAD WITH MIG TORCH

---

Used for welding with wire spools.

### 4.4 WELDING LEAD WITH TIG TORCH (PURCHASED SEPARATELY)

---

Used for welding with filler rods using a Tungsten Electrode.

### 4.5 WELDING HELMET

---

You must **always** use a welding helmet to protect your eyes from the radiation emitted from the welding arc. Using a welding helmet allows the welder to see the progression of the weld seam, and keeping the correct distance from the electrode tip to the work piece.

## 5.0 GRAPHIC SYMBOLS AND INDICATIONS

**U1:** Rated AV input voltage (with tolerance  $\pm 10\%$ ).

**I1max:** Rated maximum input current.

**I1eff:** Maximum effective input current.

**X:** duty cycle. The ratio of given duration time/the full-cycle time.

**Note1:** This ratio shall be within 0~1, and can be indicated by percentage.

**Note2:** In this standard, the full-cycle time is 10min. For example, if the duty cycle is 60%, the load-applying time shall be 6min and the following no-load time shall be 4min.

**U0:** No-load voltage. Open circuit voltage of secondary winding.

**U2:** Load voltage.

**Output voltage of rated load:**  $U_2 = (20 + 0.04I_2) \text{ V}$ .

**A / V—A / V:** range of current regulation and corresponding load voltage.

**IP:** degree of protection, such as IP21S.



Can be used in the environment which has high risk of electric shock.



Read this operation manual carefully before use.

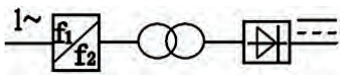

Single-phase static frequency converter-transformer rectifier.



Symbol of single-phase AC power supply and rated frequency.



Symbol of manual metal arc welding with covered electrodes.



Insulation class.



Do not dispose of electric tools together with domestic garbage.



Do not use outdoors.

## 6.0 OPERATION ENVIRONMENT

---

- Height above sea level is below 1000m.
- Operation temperature range: -10°C+40°C / 14°F~104°F.
- Relative humidity is below 90% (200°C/68°F), relative humidity is below 50% (400°C/104°F).
- The inclination of the power source does not exceed 10°.
- Protect the machine against heavy rain or in hot circumstance against direct sunlight.
- The content of dust, acid, corrosive gas in the surrounding air or substance cannot exceed normal standard.
- Take care that there is sufficient ventilation during welding. There is at least 30cm/12" free distance between the machine and wall.

## 7.0 OPERATION NOTICES

---

Read this manual carefully before attempting to use the equipment.

- Connect the ground wire with the machine directly.
- In case closing the power switch, no-load voltage may be exported. Do not touch the output electrode with any part of your body.
- Before operation, non-essential personnel should leave.  
Do not watch the arc with unprotected eyes.
- Ensure good ventilation of the machine to improve duty cycle ratio.
- Turn off the machine when the operation finished to economize energy source.
- When power switch shuts off protectively because of failure. Don't restart it until problem is resolved. Otherwise, the range of problem will be extended.

# PFC TECHNOLOGY

Reduces energy consumption up to 50% considering the model of conventional type welding machine and enables usage of energy in high efficiency and high quality.

Supply **Voltage** and **Current** over time comparison (under steady load):

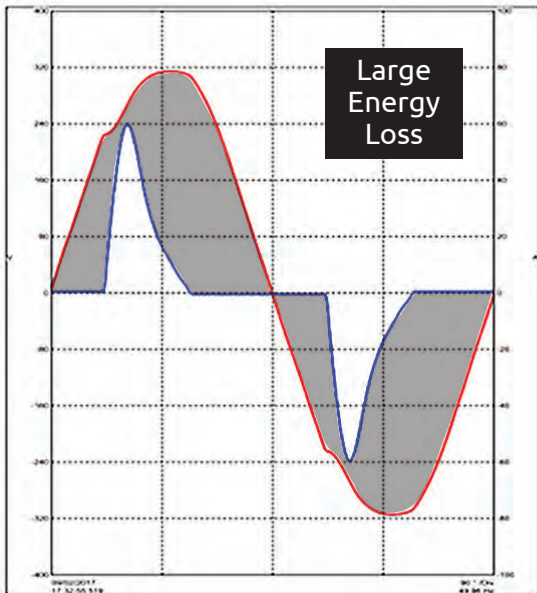

WITHOUT PFC

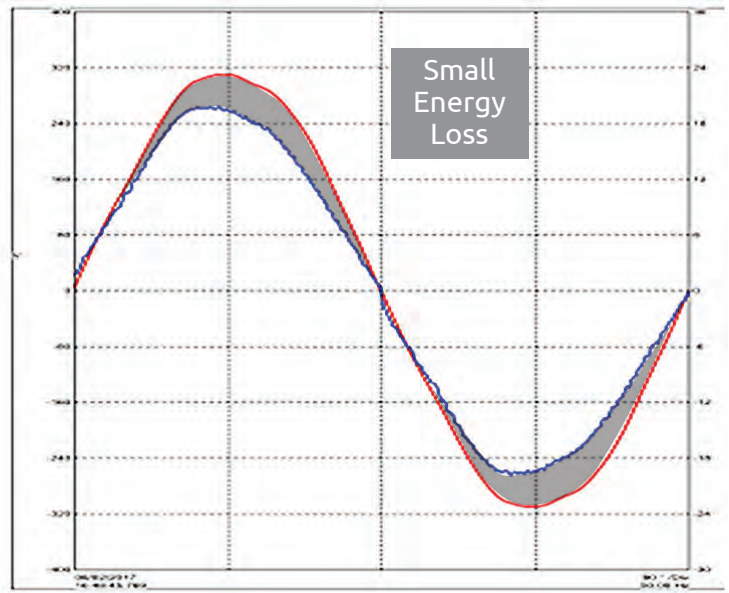

WITH PFC

Welding Current stability comparison (under steady load):

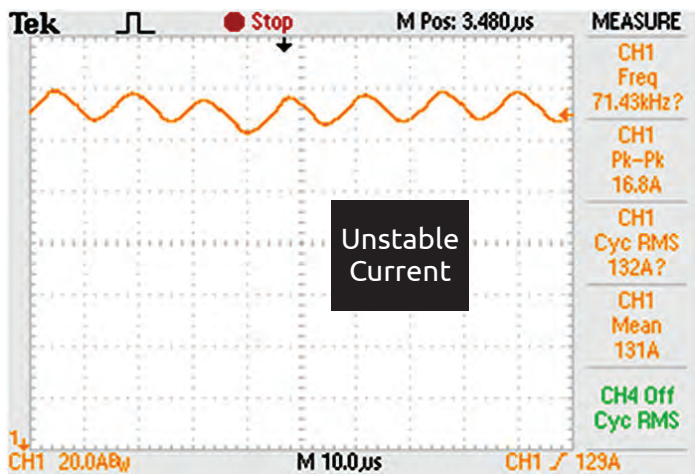

WITHOUT PFC

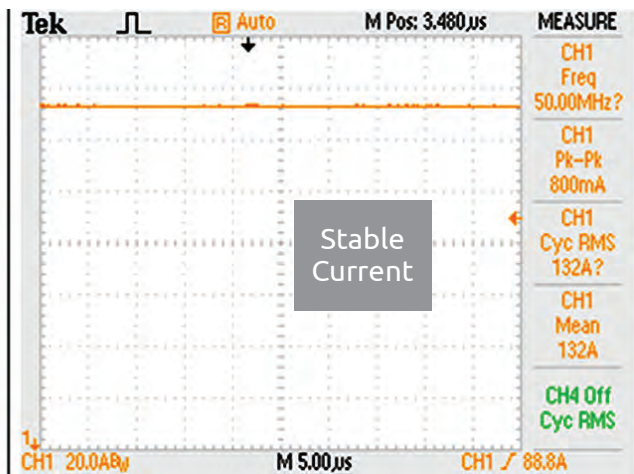

WITH PFC

# WARRANTY CARD

**3** year warranty



Customer Name: \_\_\_\_\_

Address: \_\_\_\_\_

Email: \_\_\_\_\_

Tel Number: \_\_\_\_\_

Date Of Purchase: \_\_\_\_\_

Serial Number:

Model Number: \_\_\_\_\_

Dealers Name: \_\_\_\_\_

Dealers Signature And Stamp:

## WARRANTY TERMS:

1. The warranty is valid for three years for any manufacturing defect.
2. This warranty is canceled if this certificate is not sent immediately upon purchase with tax invoice attached.
3. This warranty is canceled if the machine opened or disassemble not in the company labs.
4. The warranty is not valid if the equipment is maliciously damaged, or by negligence or accident.
5. In any case of use other than according to instructions the manufacturer's warranty is not valid.



Customer Name: \_\_\_\_\_

Address: \_\_\_\_\_

Email: \_\_\_\_\_

Tel Number: \_\_\_\_\_

Date Of Purchase: \_\_\_\_\_

Serial Number:

Model Number: \_\_\_\_\_

Dealers Name: \_\_\_\_\_

Dealers Signature And Stamp:



**Please send this attachment within 14 days of purchase!**



**Weldcote Metals**  
842 Oak Grove Road,  
Kings Mountain, NC 28086 USA.  
Phone: 704-739-4115  
[www.weldcotemetals.com](http://www.weldcotemetals.com)

**DEAR CONSUMER:**  
**Read before you turn on your device - keep this page**

**GENERAL INSTRUCTIONS:**

We recommend that you attach your warranty card showing date of purchase, to the product and keep for your reference.

**Warranty coverage terms:**

1. Warranty covers any manufacturing technical defects excluding breakage.
2. Warranty is void if repaired without our consent.
3. The warranty does not cover damage resulting from wrong operation, careless handling, accidents, misuse, entry of water, slurry, powder and other particles inside the machine, wrong installation by using wrong voltage, or in any way tampered with.
4. Only electronic components inside can be repaired for any manufacturing defects during warranty period.



**The warranty is valid under the following conditions:**

- Stamped and signed by the seller.
- The warranty certificate arrived at the WELDCOTE offices within 14 days of the purchase, together with an invoice.



**Weldcote Metals**  
842 Oak Grove Road,  
Kings Mountain, NC 28086 USA.  
Phone: 704-739-4115  
[www.weldcotemetals.com](http://www.weldcotemetals.com)

